

AUTOCLEAR 5333

Portable, Compact Parcel X-ray For Explosives, Weapons & Narcotics



***Lower profile, bottom-up design makes items and fine lines much sharper and larger on-screen.**

Control Screening is the leading worldwide producer of fast, reliable and sophisticated X-ray, Metal and Trace Detection screening systems. Visit us at www.controlscreening.com. Ask about our mobile and cargo systems. Our advanced systems and options are often integrated, leased or rented.

The AUTOCLEAR® 5333 (featuring a 53 cm wide x 33 cm high or 20.9" wide x 13" high tunnel opening) is a compact, lightweight and ergonomic conveyORIZED X-ray system designed to inspect briefcases, purses, cameras, laptops, backpacks, shoes, mailbags, bins and parcels. Ideal for use at:

- Schools • Courthouses
- Correctional Facilities
- Corporate Facilities • Mailrooms
- Embassies
- Government Buildings
- Special Events • Airports
- Military Bases • Banks
- Police Stations
- Nightclubs • Law Firms
- Executive Mail

Features

- ➔ 90 kV, 10mm penetration is standard, double the penetration available elsewhere, eliminating hand searches and improving image quality.
- ➔ Ergonomic height and smaller footprint enhances security and fits in narrow doorways, elevators and spaces; conveyor folds for transport.
- ➔ Parcel contents are displayed at normal scale, wherever located, automatically and without distortion (autoScale®). RealClear® function reveals components of dense items in realtime without lags or delays.
- ➔ Features Pentium 4, 17" monitor, RealClear®, autoScale®, autoDensAlert®, autoOutline®, autoSensing®, autoCal®, 64X Smart Zoom, Lighten, Help, DensityScan, and Low Density Stripping, among other features.
- ➔ Multi-Energy Color option with Organic/Inorganic Stripping is popular. TIP, Training and Image Archiving also available. autoMatalert®, option highlights suspect materials using atomic number and density.
- ➔ autoTracking® guided conveyor belt system never needs adjustment, lowering operating costs.
- ➔ autoSensing® eliminates the need for troublesome photosensors or footpad switch. Assures 100% screening of thin blades or plastique in magazines or courier envelopes, or of bag already in tunnel at start-up.
- ➔ Interactive training and highly responsive local service. Engineered, made and rigorously tested in the USA to ISO 9001 and regulatory standards.



RealClear® reveals components of a gun, knife, narcotics in bottle, and bomb in real time, without lags and delays. autoScale® displays contents at Pentium 4 resolution automatically and without distortion.



User-friendly, ergonomic and fully-featured operator control panel.

70 years of leadership in checkpoint detection & training

AUTOCLEAR

autoclearus.com

Scintrex® • CheckGate® • Dynavision® • Control Screening® • Federal Labs®
U.S. Canada France UK UAE Japan Latin America Singapore Spain

Model 5333 Compact X-ray Specifications

Overall Dimensions: Inspection Capabilities

Tunnel Size:	125.4 cm (49.4") L x 72.1 cm (28.4") W x 111.4 cm (43.6") H
Material Penetration:	20.9" wide (53 cm)
Contrast Sensitivity:	13" high (33 cm)
Resolution:	L-shaped detector for 100% package screening.
Processing:	10 mm (0.39") steel, twice the penetration in its class.
Conveyor Speed:	Over 2 million color tones standard.
Pulling Weight:	40 AWG wire.
autoTracking®:	32-bit adaptive image processing with minimum 128 Mbytes memory; 800 MHz or 2.4 GHz processor.
Film Safety:	48 feet per minute; 24 cm per second.
	150 kg (331 lbs) standard; 403.2 kg (887 lbs) option
	Belt guaranteed to autoTrack for life.
	Guaranteed for high-speed films up to ISO 1600 (33 DIN).
	Reduces downtime and assures all magazines, envelopes or items are scanned, no matter how thin, or of bag already in tunnel at start-up. Enhances radiation safety.

X-ray Generator

X-ray tube head:	Self-contained
High voltage rating:	90 kV standard
Duty cycle:	100% with sealed oil bath cooling
Beam orientation:	Diagonal (80° beam divergence)
Dose rate per exam:	0.1 mR. Lower doses available.

X-ray Detectors

Surface mounted, multilayer, fully integrated, high frequency, solid state detectors using high speed processors, and Pentium 4 image processing with Single Energy or optional Multi-Energy (M) Color.

Video

Standard with color 17" SVGA monitor. High resolution, flicker-free, .21 dot pitch, low rad. monitor, 1280 x 1024 video card. Single energy color is based on object density. Multi-Energy color option available with available second monitor or flat screen or larger monitor(s), displays organics in orange and inorganics in blue, both overlapping in green and very dense objects in black, and includes Organic and Inorganic Stripping.

Standard Features

- RealClear®
- autoDensAlert®
- autoTracking®
- autoSensing®
- autoOutline®
- autoScale®
- autoCal®
- 64X smart zoom
- Dark & Light enhance
- DensityScan
- Color; Reverse B/W
- High/Low Density & Stripping
- High density
- Brushed aluminum tunnel extensions
- Help
- Fast (25 second) initial warm-up
- Fully functional, robust, low profile
- Reversible conveyor direction

Options

- Multi-Energy (M) color material identification with organic and inorganic stripping
- Threat Image Projection (TIP)
- autoMatalert®
- Tropical Humidity Kit
- Loading or exit trays or rollerbeds
- Image Archiving
- LCD, dual or larger monitors
- Locking metal keypad cover
- Clear Lexan conveyor cover
- CE marking or UK approved
- kV, mA meter or item counter
- Power conditioner, or UPS
- Footpad or optical On/Off
- Variable height keypad mount
- Locking monitor hood
- Remote operation; printer or VCR cable
- Built-in Training
- Rental or leases
- Rollerbeds
- autoNet
- TipNet

Physical Details

Dimensions:	See drawing
Weight:	520 lbs (236 kg) (including undercarriage) 690 lbs (313 kg) crated
Construction:	Unibody heavy gauge epoxy painted steel construction with stainless steel and aluminum trim and accessories. Non-marring casters. Corrosion-resistant command center keypad mounted on side or on available table.
Environmental Conditions:	Temperature range: 32° - 104°F, (0° - 40°C) Humidity 20% - 95%, non-condensing. Storage to 65°C (149°F)
Electrical Power Requirements:	Consumption: < 0.7 kVA 100, 120, 230 volts AC + 10%, < 7 amps. 200, 220, 230, 240, 250 volts AC ± 10%, < 3.5 amps. All at 50 or 60 Hz.

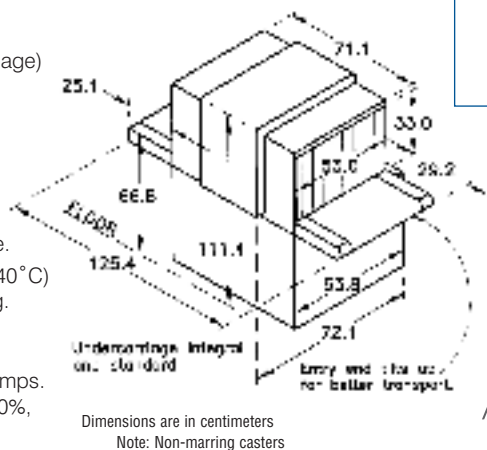

www.autoclearus.com

World Headquarters Plant

2 Gardner Road
Fairfield, NJ 07004-2206 USA
Tel: + 1 (973) 276-6161
Fax: + 1 (973) 276-6162
leads@autoclearus.com

Central EU

eu@autoclearus.com
Tel: + 33 2 38 61 97 00
Fax: + 33 2 38 61 97 01

Southern EU

seu@autoclearus.com
Tel/Fax: + 34 91 650 89 86

Northern EU

neu@autoclearus.com
UK Tel: + 44 1924 281766

Canada & Scintrex

info@scintrextrace.com
300 Parkdale Ave., Ottawa
Ontario, Canada K1Y 1G2
Tel: + 1 (613) 224-1061
Fax: + 1 (613) 224-2603

Asia Southeast & North

sasia@autoclearus.com
nasia@autoclearus.com

Latin America

latina@autoclearus.com
Dom. Republic

Middle East

me@autoclearus.com
Dubai, UAE
Tel: + 971 6 557 4505
Fax: + 971 6 557 4507

Western U.S.

nw@autoclearus.com
sw@autoclearus.com

Distributor:

ISO 9001-2000 Certified

www.autoclearus.com
www.tracedetection.com www.fed-labs.com

70 years leading innovation in
checkpoint detection & training

AUTOCLEAR
autoclearus.com

Scintrex® • CheckGate® • Dynavision® • Control Screening® • Federal Labs®
U.S. Canada France UK UAE Japan Latin America Singapore Spain