

AUTOCLEAR 6040

High Capacity Parcel X-ray for Explosives, Weapons & Narcotics



RealClear® reveals components of a gun, knife and bomb in real time, without lags and delays. autoScale® displays contents at Pentium 4 resolution automatically and without distortion.



User-friendly, ergonomic and fully-featured operator control panel.

Control Screening is the leading worldwide producer of fast, reliable and sophisticated X-ray, Metal and Trace Detection screening systems. Visit us at www.controlscreening.com. Ask about our mobile and cargo systems. Our advanced systems and options are often integrated, leased or rented.

The AUTOCLEAR® 6040 (featuring a 60.0 cm wide x 40.0 cm high or 24.4" wide x 16.5" high tunnel opening) is a high capacity, high penetration, heavy-duty, conveyORIZED X-ray scanner designed to inspect carry-on bags, briefcases, mail trays and parcels. Ideal for use at:

**Airports • Seaports • Courts
Customs • Corporate Facilities
Government Buildings • Postal
Checkpoints • Loading Docks
Mailrooms • Corrections Facilities
Nuclear • Access Control
Special Events • Hospitals
Rail or Bus Stations
Police Stations • Military Bases**

Features

- ▶ autoTracking® guided conveyor belt system never needs adjustment, lowering operating costs.
- ▶ autoSensing® eliminates the need for troublesome photosensors or footpad switch. Assures 100% screening of thin blades or plastique in magazines or courier envelopes, or of bag already in tunnel at start-up.
- ▶ Parcel contents are displayed at normal scale, wherever located, automatically and without distortion (autoScale®). RealClear® function reveals components of dense items in realtime without lags or delays.
- ▶ Narrower footprint enhances security and conveniently fits in elevators, 32" doorways and tight spaces; conveyor end folds up for transport.
- ▶ Features Pentium 4, 17" monitor, RealClear®, autoScale®, autoDensalert®, autoOutline®, autoSensing®, autoCal®, 64X Smart Zoom, Lighten, Help, DensityScan, and Low Density Stripping, among other features.
- ▶ Compact version (above) or airport version with extended conveyor(s).
- ▶ Multi-Energy Color option with Organic/Inorganic Stripping is popular. TIP, Training and Image Archiving also available. autoMatalert®, option highlights suspect materials using atomic number and density.
- ▶ Interactive training and highly responsive local service. Engineered, made and rigorously tested in the USA to ISO 9001 and regulatory standards

70 years of leadership in checkpoint detection & training

AUTOCLEAR

autoclearus.com

Scintrex® • CheckGate® • Dynavision® • Control Screening® • Federal Labs®
U.S. Canada France UK UAE Japan Latin America Singapore Spain

Model 6040 X-ray Specifications

Overall Dimensions: Inspection Capabilities

Tunnel Size:	154.6 cm (60.9") L x 80.9 cm (31.9") W x 126.4 cm (49.8") H
Material Penetration:	24.4" wide (60 cm)
Contrast Sensitivity:	16.5" high (40 cm)
Resolution:	L-shaped detector for 100% package screening.
Processing:	28-29 mm steel
Conveyor Speed:	Over 2 million color tones standard.
	40 AWG wire.
	32-bit adaptive image processing with minimum 128 Mbytes memory; 2.4+ GHz processor.
	48 feet per minute; 24 cm per second. Standard conveyor pictured on reverse. Extended conveyor length, Model 6040E (variable length entrance and exit bed). Fully reversible.

Pulling Weight:	150 kg (331 lbs) (Higher pulling weights available).
autoTracking®:	Belt guaranteed to autoTrack for life.
Film Safety:	Guaranteed for high-speed films up to ISO 1600 (33 DIN).
*Full autoSensing® without photosensors, moving parts, or footprint.	
Reduces downtime and assures all magazines, envelopes or items are scanned, no matter how thin, or of bag already in tunnel at start-up. Enhances radiation safety.	

X-ray Generator

X-ray tube head:	Self-contained, shielded tank
High voltage rating:	160 kV, 140 kV Operating Voltage
Duty cycle:	100% with sealed oil bath cooling
Beam orientation:	Diagonal (80° beam divergence)
Dose rate per exam:	0.1 mR. Lower doses available.

X-ray Detectors

Surface mounted, multilayer, fully integrated, high frequency, solid state detectors using high speed processors, and Pentium 4 image processing with Single Energy or optional Multi-Energy (M) Color.

Video

Standard with color 17" SVGA monitor. High resolution, flicker-free, .21 dot pitch, low rad. monitor, 1280 x 1024 video card. Single energy color is based on object density. Multi-Energy color option available with available second monitor or flat screen or larger monitor(s), displays organics in orange and inorganics in blue, both overlapping in green and very dense objects in black, and includes Organic and Inorganic Stripping.

Standard Features

- RealClear®
- autoDensAlert®
- autoTracking®
- autoSensing®
- autoOutline®
- autoScale®
- autoCal®
- 64X smart zoom
- Dark & Light enhance
- DensityScan
- Color; Reverse B/W
- High/Low Density & Stripping
- High density
- Help
- Fast (25 second) initial warm-up
- Fully functional, robust, low profile
- Reversible conveyor direction

Options

- Multi-Energy organic and inorganic color & stripping
- autoMatalert®
- Threat Image Projection (TIP)
- Rollerbed(s) or conveyor extensions
- Tropical Humidity Kit
- Image Archiving
- CE marking or UK approved
- Power conditioner, or UPS
- Table or locking monitor hood
- Locking metal keypad cover
- kV, mA meter or item counter
- LCD, dual or larger monitor(s)
- Footpad or optical on/off
- Variable height keypad mount
- Clear Lexan conveyor cover
- Remote operation, printer or VCR cable
- Highspeed Conveyor
- Built-in Training
- Rentals or leases
- autoNet
- TipNet

Physical Details

Dimensions:	See drawing
Weight:	775 lbs (352 kg) 975 lbs (442 kg) crated
Construction:	Unibody heavy gauge, epoxy painted steel construction with stainless steel and aluminum trim and accessories. Non-marring casters and leveling jackscrews. Corrosion-resistant command center keypad mounted on side or available table.
Environmental Conditions:	Temperature range: 32° - 104°F, (0° - 40°C) Humidity 20% - 95%, non-condensing. Storage to 65°C (149°F)
Electrical Power Requirements:	Consumption: < .8 kVA, 100, 120 volts AC ± 10% (<8 amps) 200, 220, 230, 240, 250 volts AC ± 10% (<4 amps). All at 50 or 60 Hz.

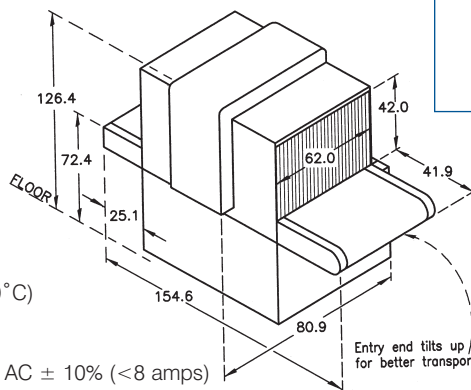

Dimensions are in centimeters
Note: Non-marring casters

www.autoclearus.com

World Headquarters Plant

2 Gardner Road
Fairfield, NJ 07004-2206 USA
Tel: + 1 (973) 276-6161
Fax: + 1 (973) 276-6162
leads@autoclearus.com

Central EU

eu@autoclearus.com
Tel: + 33 2 38 61 97 00
Fax: + 33 2 38 61 97 01

Southern EU

seu@autoclearus.com
Tel/Fax: + 34 91 650 89 86

Northern EU

neu@autoclearus.com
UK Tel: + 44 1924 281766

Canada & Scintrex

info@scintrextrace.com
300 Parkdale Ave., Ottawa
Ontario, Canada K1Y 1G2
Tel: + 1 (613) 224-1061
Fax: + 1 (613) 224-2603

Asia Southeast & North

sasia@autoclearus.com
nasia@autoclearus.com

Latin America

latina@autoclearus.com
Dom. Republic

Middle East

me@autoclearus.com
Dubai, UAE
Tel: + 971 6 557 4505
Fax: + 971 6 557 4507

Western U.S.

nw@autoclearus.com
sw@autoclearus.com

Distributor:

ISO 9001-2000 Certified

www.autoclearus.com
www.tracedetection.com www.fed-labs.com

70 years leading innovation
in checkpoint detection & training

AUTOCLEAR
autoclearus.com

Scintrex® • CheckGate® • Dynavision® • Control Screening® • Federal Labs®
U.S. Canada France UK UAE Japan Latin America Singapore Spain