

# AUTOCLEAR 6848

## High Capacity Parcel X-ray for Explosives, Weapons & Narcotics



RealClear® reveals components of a gun, knife and bomb in real time, without lags and delays. autoScale® displays contents at Pentium 4 resolution automatically and without distortion.



User-friendly, ergonomic and fully-featured operator control panel.

Control Screening is the leading worldwide producer of fast, reliable and sophisticated X-ray, Metal and Trace Detection screening systems. Visit us at [www.controlscreening.com](http://www.controlscreening.com). Ask about our mobile and cargo systems. Our advanced systems and options are often integrated, leased or rented.

The AUTOCLEAR® 6848 (featuring a 68.0 cm wide x 48.0 cm high or 26.8" wide x 18.9" high tunnel opening) is a high capacity, high penetration, heavy-duty, conveyORIZED X-ray scanner designed to inspect carry-on bags, briefcases, mail trays and parcels. Ideal for use at:

**Airports • Seaports • Courts  
Customs • Corporate Facilities  
Government Buildings • Postal  
Checkpoints • Loading Docks  
Mailrooms • Corrections Facilities  
Nuclear • Access Control  
Special Events • Hospitals  
Rail or Bus Stations  
Police Stations • Military Bases**

### Features

- ➔ autoTracking® guided conveyor belt system never needs adjustment, lowering operating costs.
- ➔ autoSensing® eliminates the need for troublesome photosensors or footpad switch. Assures 100% screening of thin blades or plastique in magazines or courier envelopes, or of bag already in tunnel at start-up.
- ➔ Parcel contents are displayed at normal scale, wherever located, automatically and without distortion (autoScale®). RealClear® function reveals components of dense items in realtime without lags or delays.
- ➔ Narrower footprint enhances security and conveniently fits in elevators, 36" doorways and tight spaces; conveyor end folds up for transport.
- ➔ Features Pentium 4, 17" monitor, RealClear®, autoScale®, autoDensAlert®, autoOutline®, autoSensing®, autoCal®, 64X Smart Zoom, Lighten, Help, DensityScan, and Low Density Stripping, among other features.
- ➔ Compact version (above) or airport version with extended conveyor(s).
- ➔ Multi-Energy Color option with Organic/Inorganic Stripping is popular. TIP, Training and Image Archiving also available. autoMatalert®, option highlights suspect materials using atomic number and density.
- ➔ Interactive training and highly responsive local service. Engineered, made and rigorously tested in the USA to ISO 9001 and regulatory standards

*70 years of leadership in checkpoint detection & training*

# AUTOCLEAR

[autoclearus.com](http://autoclearus.com)

Scintrex® • CheckGate® • Dynavision® • Control Screening® • Federal Labs®  
U.S. Canada France UK UAE Japan Latin America Singapore Spain

# Model 6848 X-ray Specifications

## Overall Dimensions: Inspection Capabilities

	185.4 cm (73.0") L x 88.1 cm (34.7") W x 132.7 cm (52.3") H
Tunnel Size:	26.8" wide (68 cm) 18.9" high (48 cm) L-shaped detector for 100% package screening.
Material Penetration:	28-29 mm steel
Contrast Sensitivity:	Over 2 million color tones standard.
Resolution:	40 AWG wire.
Processing:	32-bit adaptive image processing with minimum 128 Mbytes memory; 800 MHz or 2.4 GHz processor.
Conveyor Speed:	48 feet per minute; 24 cm per second. Standard conveyor pictured on reverse. Extended conveyor length, Model 6040E (variable length entrance and exit bed). Fully reversible.
Pulling Weight:	150 kg (331 lbs) (Higher pulling weights available).
autoTracking®:	Belt guaranteed to autoTrack for life.
Film Safety:	Guaranteed for high-speed films up to ISO 1600 (33 DIN).

**\*Full autoSensing® without photosensors, moving parts, or footpad.**

**Reduces downtime and assures all magazines, envelopes or items are scanned, no matter how thin, or of bag already in tunnel at start-up. Enhances radiation safety.**

## X-ray Generator

X-ray tube head:	Self-contained, shielded tank
High voltage rating:	160 kV, 140 kV Operating Voltage
Duty cycle:	100% with sealed oil bath cooling
Beam orientation:	Diagonal (80° beam divergence)
Dose rate per exam:	0.1 mR. Lower doses available.

## X-ray Detectors

Surface mounted, multilayer, fully integrated, high frequency, solid state detectors using high speed processors, and Pentium 4 image processing with Single Energy or optional Multi-Energy (M) Color.

## Video

Standard with color 17" SVGA monitor. High resolution, flicker-free, .21 dot pitch, low rad. monitor, 1280 x 1024 video card. Single energy color is based on object density. Multi-Energy color option available with available second monitor or flat screen or larger monitor(s), displays organics in orange and inorganics in blue, both overlapping in green and very dense objects in black, and includes Organic and Inorganic Stripping.

## Standard Features

- RealClear®
- autoDensAlert®
- autoTracking®
- autoSensing®
- autoOutline®
- autoScale®
- autoCal®
- Dark & Light enhance
- DensityScan
- Color; Reverse B/W
- High/Low Density & Stripping
- High density
- Help
- Fast (25 second) initial warm-up
- Fully functional, robust, low profile
- Reversible conveyor direction

## Options

- Multi-Energy organic and inorganic color & stripping
- autoMatalert®
- Threat Image Projection (TIP)
- Rollerbed(s) or conveyor extensions
- Tropical Humidity Kit
- Image Archiving
- CE marking or UK approved
- Power conditioner, or UPS
- Table or locking monitor hood
- Locking metal keypad cover
- kV, mA meter or item counter
- LCD, dual or larger monitor(s)
- Footpad or optical on/off
- Variable height keypad mount
- Clear Lexan conveyor cover
- Remote operation, printer or VCR cable
- Built-in Training
- Rentals or leases
- autoNet
- TipNet

## Physical Details

Dimensions:	See drawing
Weight:	890 lbs (403 kg) 1150 lbs (517 kg) crated
Construction:	Unibody heavy gauge, epoxy painted steel construction with stainless steel and aluminum trim and accessories. Non-marring casters and leveling jackscrews. Corrosion-resistant command center keypad mounted on side or on available table.
Environmental Conditions:	Temperature range: 32° - 104°F, (0° - 40°C) Humidity 20% - 95%, non-condensing. Storage to 65°C (149°F)
Electrical Power Requirements:	Consumption: < .6 kVA, 100, 120 volts AC ± 10% (-6 amps) 200, 220, 230, 240, 250 volts AC ± 10% (<3 amps). All at 50 or 60 Hz.

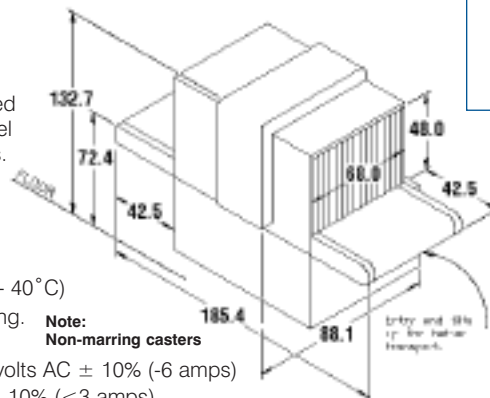

Dimensions are in centimeters

[www.autoclearus.com](http://www.autoclearus.com)

## World Headquarters Plant

2 Gardner Road  
Fairfield, NJ 07004-2206 USA  
Tel: + 1 (973) 276-6161  
Fax: + 1 (973) 276-6162  
leads@autoclearus.com

## Central EU

eu@autoclearus.com  
Tel: + 33 2 38 61 97 00  
Fax: + 33 2 38 61 97 01

## Southern EU

seu@autoclearus.com  
Tel/Fax: + 34 91 650 89 86

## Northern EU

neu@autoclearus.com  
UK Tel: + 44 1924 281766

## Canada & Scintrex

info@scintrextrace.com  
300 Parkdale Ave., Ottawa  
Ontario, Canada K1Y 1G2  
Tel: + 1 (613) 224-1061  
Fax: + 1 (613) 224-2603

## Asia Southeast & North

sasia@autoclearus.com  
nasia@autoclearus.com

## Latin America

latina@autoclearus.com  
Dom. Republic

## Middle East

me@autoclearus.com  
Dubai, UAE  
Tel: + 971 6 557 4505  
Fax: + 971 6 557 4507

## Western U.S.

nw@autoclearus.com  
sw@autoclearus.com

## Distributor:

ISO 9001-2000 Certified

[www.autoclearus.com](http://www.autoclearus.com)  
[www.tracedetection.com](http://www.tracedetection.com) [www.fed-labs.com](http://www.fed-labs.com)

70 years leading innovation in  
checkpoint detection & training

AUTOCLEAR  
autoclearus.com

Scintrex® • CheckGate® • Dynavision® • Control Screening® • Federal Labs®  
U.S. Canada France UK UAE Japan Latin America Singapore Spain