

AUTOCLEAR Mailguard®

Simple Compact X-ray



Our improved **Mailguard®** letter and parcel X-ray security screening system is designed for confined spaces, tight corners, placement against walls, for desktop operation or on our available cart. The **Mailguard®** measures 22.5" wide x 23.5" deep x 30.5" high (57.2 cm x 59.7 cm x 77.5 cm).

The **Mailguard®** is ideally suited for the rapid detection of contraband materials in mail, briefcases, backpacks, clothing, electronic devices, purses, cameras, shoes, mailbags, bins, coats, bedding, or parcels, in:

Mailrooms • Corporate Offices
Embassies • Prisons
Executive Mail (Office or Home)
Banks • Hotels • Courtrooms
Quality Control • Police
Government Offices

or anywhere that suspect material must be screened and detected.

FEATURES:

- Higher penetrating and more efficient, proven 90kV X-ray source, designed and made in America.
- Extra fine grain resolution, with greater brightness, for a very sharp image.
- Larger parcels, higher throughput: compartment size - 21" x 18" x 14" (53.3cm x 45.7cm x 35.6cm) - than other similar models, at less cost.
- The **Mailguard®** operates more simply than a small office copier. Through advanced design, the **Mailguard®** (excluding available table or cart) is only 30.5" (77.5 cm) high.
- Double the penetration and throughput of other cabinet X-ray systems. Proven, proprietary double interlocking door and shielding.
- Examines over 400 batches per hour, 200-500 standard envelopes per batch. Takes parcels up to 21" x 18" x 14" (53.3cm x 45.7cm x 35.6cm).
- Safer than other fluoroscopes, due to unique double interlocking, double-thick viewing port and lower operating mA power.
- Very easy to install, operate and maintain.
- Often used for (highly cost effective) quality assurance, forensics and non-destructive testing, as well as security.
- No moving parts. Thousands in government use worldwide, with worldwide support.

70 years of leadership in checkpoint detection & training

AUTOCLEAR

autoclearus.com

Scintrex® • CheckGate® • Dynavision® • Control Screening® • Federal Labs®
U.S. Canada France UK UAE Japan Latin America Singapore Spain

Mailguard® Simple, Compact X-ray Specifications

X-ray Generator Capability

Rated 90 kV constant potential peak, high reliability, high frequency X-ray generator. Not film-safe. If film-safety, color monitor or full digital or color functionality is required, visit autoclearus.com or call for AUTOCLEAR Desktop 3920 or externally conveyORIZED 4025, or larger model.
Current: 1 mA maximum.
Cooling: Sealed oil bath, air cooled.

Compartment Size

18" (45.7 cm) Wide
21" (53.3 cm) Deep
14" (35.6 cm) High

Viewing Method

Direct view

Fluoroscopic Inspection Screen Size

17" (43.2 cm) x 17" (43.2 cm)
The full screen area is imaged, but thick parcels may need to be viewed twice.

Penetration

11mm of steel equivalency.

Resolution

40 AWG Copper wire

Input Voltage and Power Requirements

110-130 volt or 210-250 volt,
(Specify voltage when ordering)
Single phase AC,
50/60 Hertz, under 250 watts

Overall Size and Weight

30.5" (77.5 cm) High
22.5" (57.2 cm) Wide
23.5" (59.7 cm) Deep
350 lbs (159 kg)
400 lbs (182 kg) crated

Radiation Safety

Dual Safety interlocks
Panel operating switch
Double shielded viewing glass
Lockable power switch
Meets or exceeds Federal Standard 21 CFR 1020.40 and all applicable International Radiation and CE Marking Standards.

Options

- Heavy-duty cart (recommended)
- Rental or lease
- Extended warranty
- CE marking
- Custom colors
- UPS

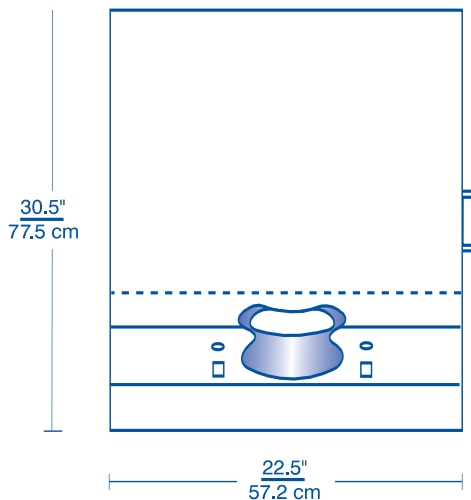
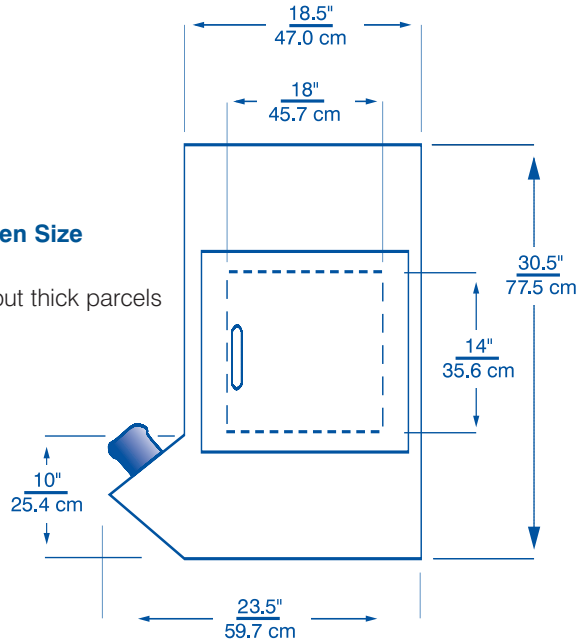

www.autoclearus.com

World Headquarters Plant

2 Gardner Road
Fairfield, NJ 07004-2206 USA
Tel: + 1 (973) 276-6161
Fax: + 1 (973) 276-6162
leads@autoclearus.com

Central EU

eu@autoclearus.com
Tel: + 33 2 38 61 97 00
Fax: + 33 2 38 61 97 01

Southern EU

seu@autoclearus.com
Tel/Fax: + 34 91 650 89 86

Northern EU

neu@autoclearus.com
UK Tel: + 44 1924 281766

Canada & Scintrex

info@scintrextrace.com
300 Parkdale Ave., Ottawa
Ontario, Canada K1Y 1G2
Tel: + 1 (613) 224-1061
Fax: + 1 (613) 224-2603

Asia Southeast & North

sasia@autoclearus.com
nasia@autoclearus.com

Latin America

latina@autoclearus.com
Dom. Republic

Middle East

me@autoclearus.com
Dubai, UAE
Tel: + 971 6 557 4505
Fax: + 971 6 557 4507

Western U.S.

nw@autoclearus.com
sw@autoclearus.com

Distributor:

ISO 9001-2000 Certified

www.autoclearus.com
www.tracedetection.com www.fed-labs.com

70 years leading innovation in checkpoint detection & training

AUTOCLEAR
autoclearus.com

Scintrex® • CheckGate® • Dynavision® • Control Screening® • Federal Labs®
U.S. Canada France UK UAE Japan Latin America Singapore Spain

Compliance Complies with the U.S. Federal Aviation Administration Standards "Use of X-Ray Systems" (Federal Standards 14 CFR 108.17 and 14 CFR 129.26; the system conforms to the USBRH Performance Standards for Cabinet X-Ray Systems (21 CFR 1020.40). The electrical system conforms to applicable sections of IEC 348 for Electrical Safety and FCC Docket 20780 for Electromagnetic capability.